

STEEL LOAD MANIPULATOR

MCH 150

Technical qualities:

The MCH 150 Steel Mini Stacker is available with 2 wheel versions:

Fixed polyamide rollers or swivel casters, depending on use.

The fixed polyamide rollers optimize the passage under machine.

The swivel casters increase its maneuverability.

With removable plastic protectors, it respects the integrity of the load you are handling.

The large handles allow a comfortable grip, whatever the size of the user.



Ref. 300707⁽¹⁾ / 300708⁽²⁾

The MCH 150 Load Manipulator is a versatile, manoeuvrable and space-saving manual lifter.

Characteristics:

- Maximum working load: 150 kg
- Lifting height: 60 à 1400 mm
- Raised by crank turn: 65 mm
- At the rear ø 60 mm swivel casters with brake
- At the front ø 60 mm swivel casters ⁽¹⁾
- Polyamide rollers (fixed) ø 50 mm ⁽²⁾
- Fork section (L x W x H): 455 x 20 x 35mm
- Center distance between forks: 330 mm
- Dimensions (L x W x H)⁽¹⁾: 912x 455x 1650 mm
- Dimensions (L x W x H)⁽²⁾: 869 x 455x 1650 mm
- Maximum total height: 2019 mm
- Net weight: 30 kg

⁽¹⁾: swivel castor version

⁽²⁾: fixed polyamide rollers versions

- Two versions available
- Robust mechanically welded structure
- Black plastic protectors, removable
- Self-braking manual winch in galvanized steel
- Light and handy

Applications:

- Workshop handling
- Coil handling

Accessories:



Platform
Ref: 300 188



V-Bed platform
Ref: 300 189

Dimensional Drawings:

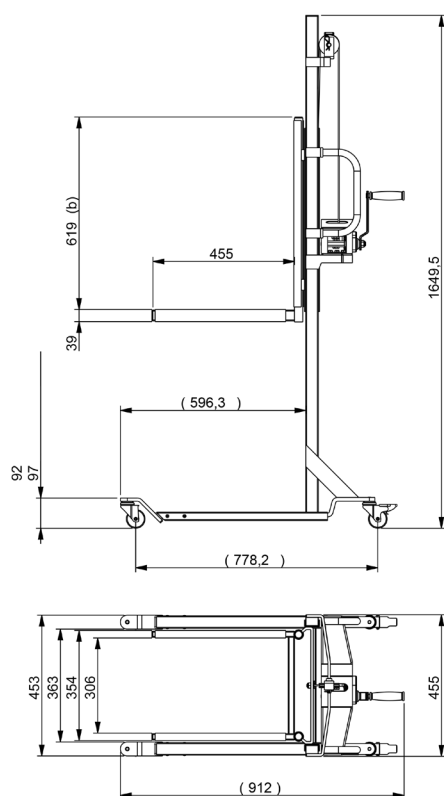

Dimensional Drawing:
swivel castor version

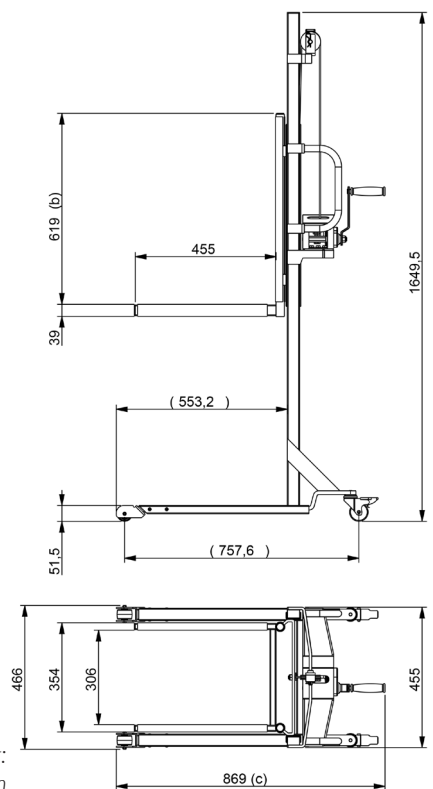

Dimensional Drawing:
fixed polyamide rollers version

Terms of use

The user is responsible for defining the products to be adapted to its own use. TELIP takes charge of submitting accurate and updated information. However, as part of the continuous improvement of its products, TELIP reserves the right to proceed with frequent modifications without warning. Therefore, TELIP cannot guarantee the accuracy and current reality of information on its products. All transactions are subject to general terms and conditions of sales and transportation. These conditions are available upon request and downloadable on the website www.telip.fr.

TELIP
MANUTENTION ET LEVAGE

TELIP
2, rue Andrée Reigner - Z. I. La Bougeoire
35 130 La Guerche de Bretagne
FRANCE

Tél. : 02 99 96 17 16
Fax : 02 99 96 17 26

contact@telip.fr
www.telip.fr